

CASTOR HPH98WC160R4E2D34



Product SKU	HPH98WC160R4E2D34
Standard Compliance	DIN EN 12532
Series	R4E2
Fastening	Bolt fastening
Material of the Wheel	polyamide (PA) wheel center
Tread	elastic tread
Temperature range	-20°C to +80°C
Wheel Diameter	160mm
Load Capacity	250kg
Total Height	189mm
Width of Tread	46mm
wheel hub Width	59mm
Offset	55mm
Fastening Bolt Hole Diameter	13mm
Wheel Bolt Size	M12
Bushing Diameter	12mm
Weight	1.67kg
Wheel Bearing	double ball bearing
Rubber Shore	65° Shore A



CASTOR HPH98WC160R4E2D34

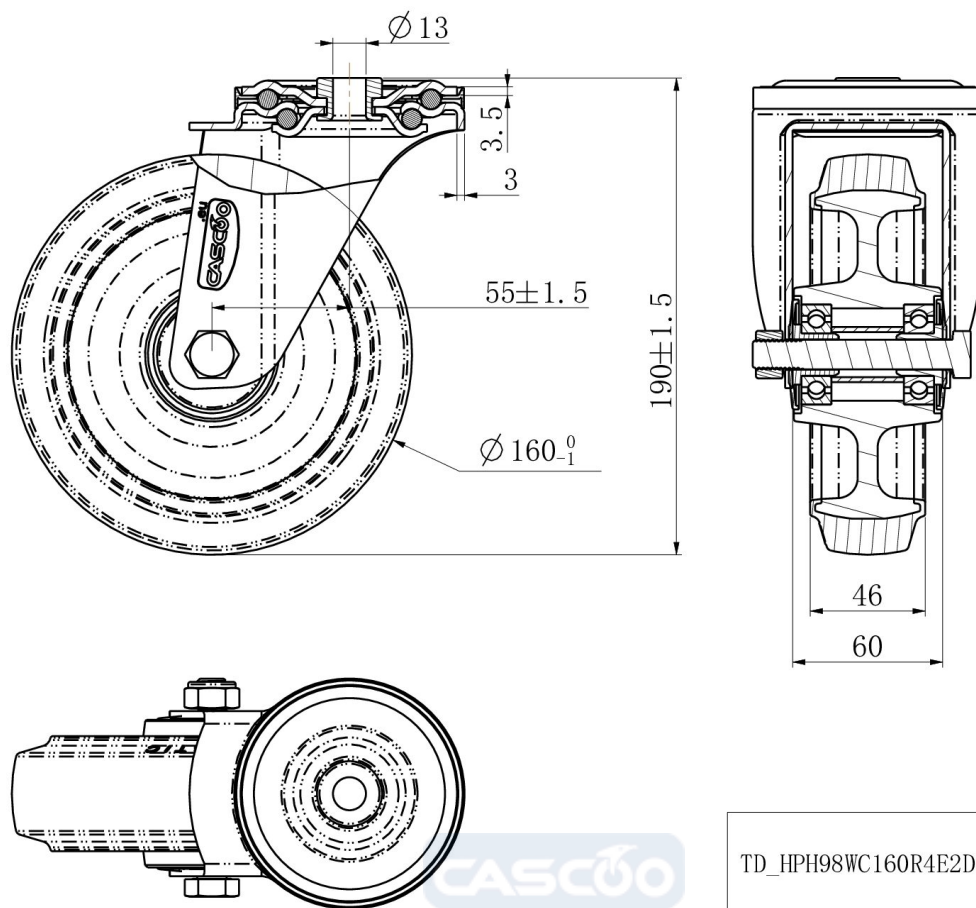

TD_HPH98WC160R4E2D34		
load capacity	250KG	