

CASTOR HPH98WC160N2U6R1W



Product SKU	HPH98WC160N2U6R1W
Standard Compliance	DIN EN 12532
Series	N2U6
Fastening	Bolt fastening
Material of the Wheel	polyamide (PA) wheel center
Tread	polyurethane (PU) tread
Temperature range	-40°C to +80°C
Wheel Diameter	160mm
Load Capacity	250kg
Total Height	189mm
Width of Tread	40mm
wheel hub Width	59mm
Offset	55mm
Fastening Bolt Hole Diameter	13mm
Wheel Bolt Size	M12
Bushing Diameter	20mm
Weight	1.58kg
Wheel Bearing	roller bearing
Rubber Shore	95° Shore A



CASTOR HPH98WC160N2U6R1W

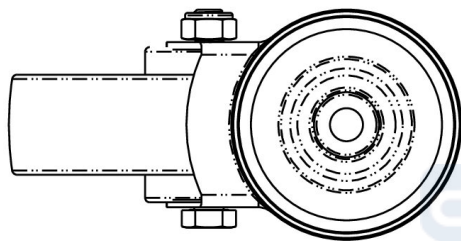
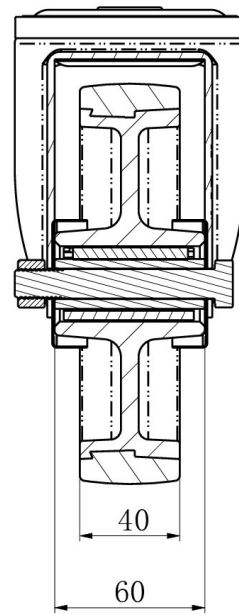
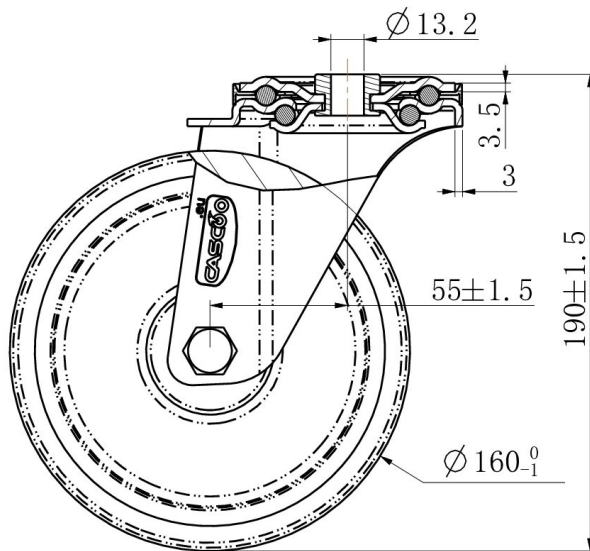

TD_HPH98WC160N2U6R1W		
load capacity	250KG	