

## CASTOR HPH85WC125N2U6B32



<b>Product SKU</b>	HPH85WC125N2U6B32
<b>Standard Compliance</b>	DIN EN 12532
<b>Series</b>	N2U6
<b>Fastening</b>	Bolt fastening
<b>Brake and Direction</b>	swivel without brake
<b>Material of the Wheel</b>	polyamide (PA) wheel center
<b>Tread</b>	polyurethane (PU) tread
<b>Temperature range</b>	-40°C to +80°C
<b>Wheel Diameter</b>	125mm
<b>Load Capacity</b>	160kg
<b>Total Height</b>	154mm
<b>Width of Tread</b>	32mm
<b>wheel hub Width</b>	50mm
<b>Offset</b>	40mm
<b>Fastening Bolt Hole Diameter</b>	13mm
<b>Wheel Bolt Size</b>	M10
<b>Bushing Diameter</b>	10mm
<b>Weight</b>	0.69kg
<b>Wheel Bearing</b>	ball bearing
<b>Rubber Shore</b>	95° Shore A



# CASTOR HPH85WC125N2U6B32

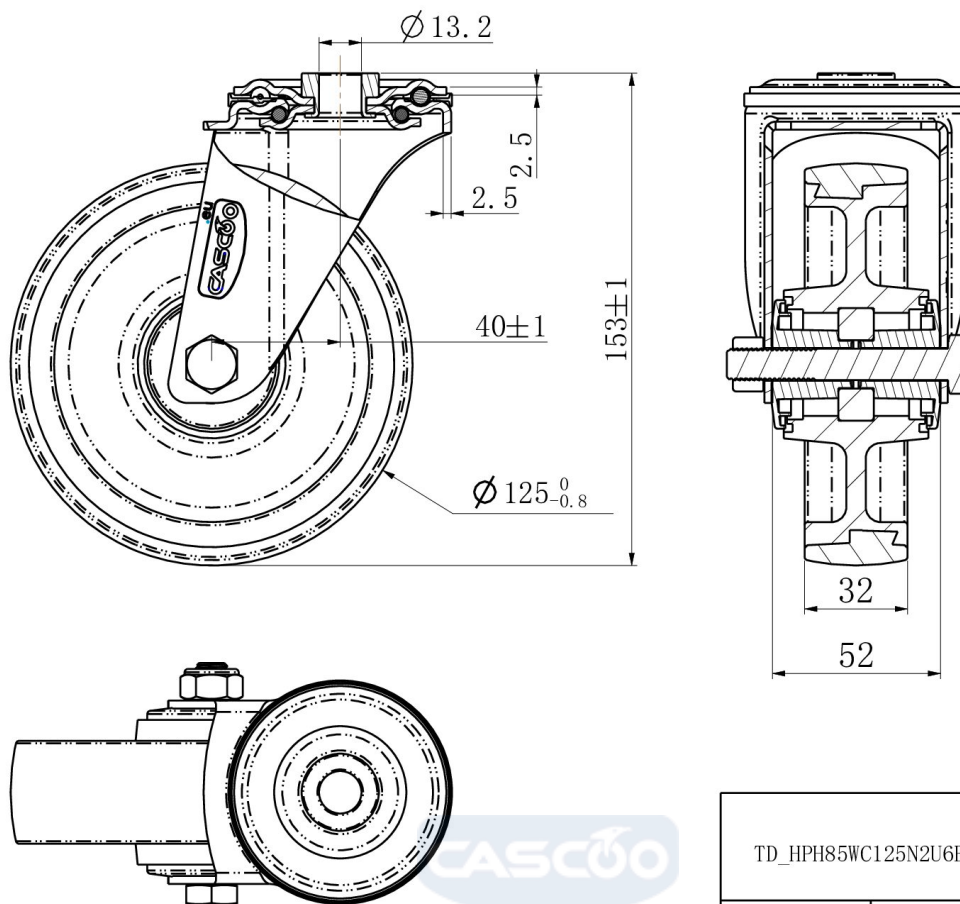

TD_HPH85WC125N2U6B32		
load capacity	150KG	