

CASTOR HBH36WC100P2G2B32A

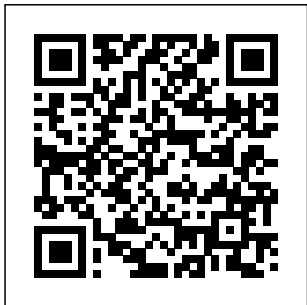

Product SKU	HBH36WC100P2G2B32A
Standard Compliance	DIN EN 12532
Series	P2G2 (antistatic)
Fastening	Bolt fastening
Brake and Direction	swivel without brake
Material of the Wheel	polypropylene (PP) wheel center
Tread	thermoplastic rubber tread
Temperature range	-20°C to +60°C
Wheel Diameter	100mm
Load Capacity	90kg
Total Height	124mm
Width of Tread	32mm
wheel hub Width	40mm
Offset	40mm
Fastening Bolt Hole Diameter	13mm
Wheel Bolt Size	M8
Bushing Diameter	8mm
Weight	0.5kg
Wheel Bearing	ball bearing
Special Features	antistatic



CASTOR HBH36WC100P2G2B32A

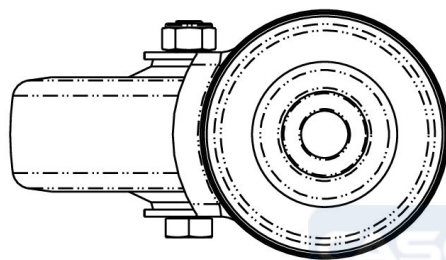
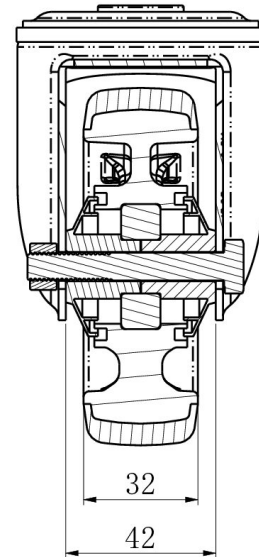
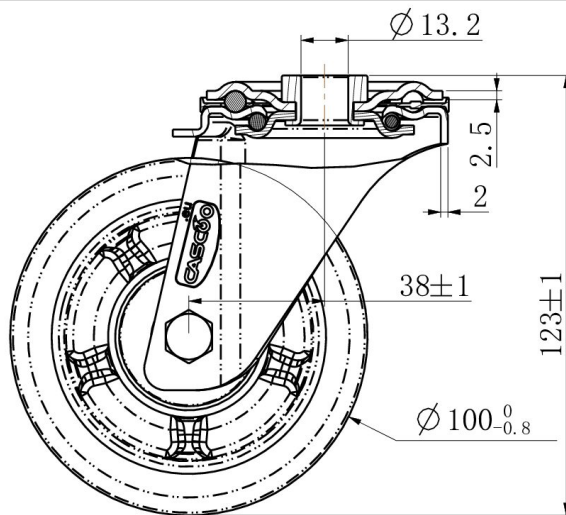

TD_HBH36WC100P2G2B32A		
load capacity	90KG	