

## CASTOR FPP53WC250P2G2D32

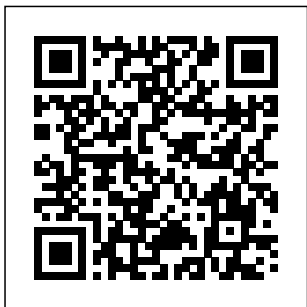

<b>Product SKU</b>	FPP53WC250P2G2D32
<b>Standard Compliance</b>	DIN EN 12532
<b>Series</b>	P2G2
<b>Fastening</b>	Plate fastening
<b>Brake and Direction</b>	fixed direction
<b>Material of the Wheel</b>	polypropylene (PP) wheel center
<b>Tread</b>	thermoplastic rubber tread
<b>Temperature range</b>	-20°C to +60°C
<b>Wheel Diameter</b>	250mm
<b>Load Capacity</b>	300kg
<b>Total Height</b>	295mm
<b>Width of Tread</b>	40mm
<b>wheel hub Width</b>	59mm
<b>Dimension of Plate</b>	135x110mm
<b>Hole Spacing of the Plate</b>	105x84/76mm
<b>Wheel Bolt Size</b>	M12
<b>Bushing Diameter</b>	12mm
<b>Weight</b>	2.07kg
<b>Wheel Bearing</b>	double ball bearing
<b>Rubber Shore</b>	70° Shore A



# CASTOR FPP53WC250P2G2D32

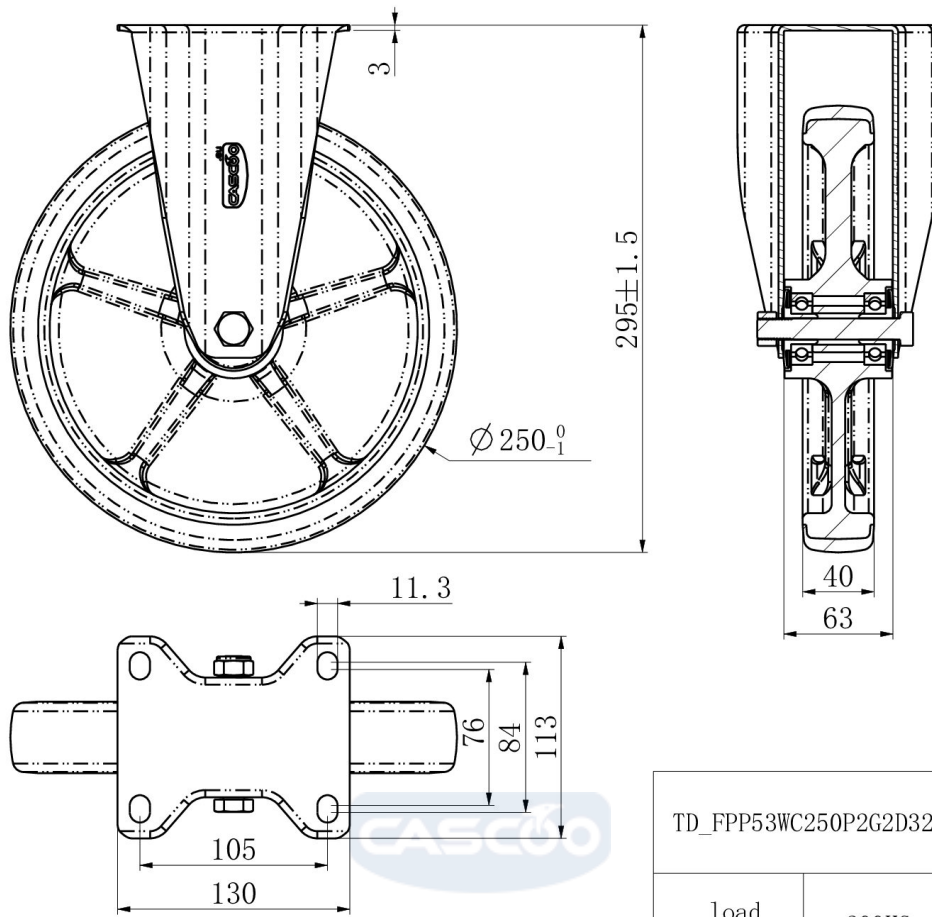

TD_FPP53WC250P2G2D32		
load capacity	300KG	