

## CASTOR FPP25WC100M6N2B32

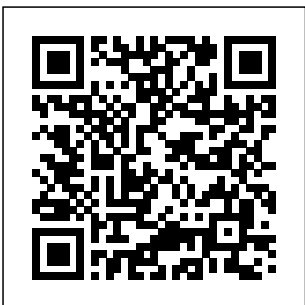

<b>Product SKU</b>	FPP25WC100M6N2B32
<b>Standard Compliance</b>	DIN EN 12532
<b>Series</b>	M6N2
<b>Fastening</b>	Plate fastening
<b>Brake and Direction</b>	fixed direction
<b>Material of the Wheel</b>	polyamide (PA) wheel center
<b>Tread</b>	polyamide (PA) tread
<b>Temperature range</b>	-20°C to +80°C
<b>Wheel Diameter</b>	100mm
<b>Load Capacity</b>	160kg
<b>Total Hight</b>	128mm
<b>Width of Tread</b>	36mm
<b>wheel hub Width</b>	40mm
<b>Dimension of Plate</b>	105x80mm
<b>Hole Spacing of the Plate</b>	80/77x60mm
<b>Wheel Bolt Size</b>	M8
<b>Bushing Diameter</b>	8mm
<b>Wheel Bearing</b>	ball bearing



# CASTOR FPP25WC100M6N2B32

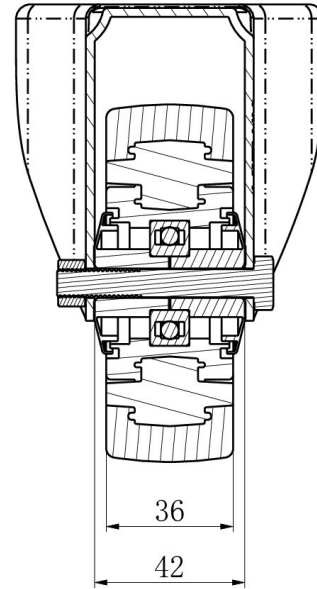
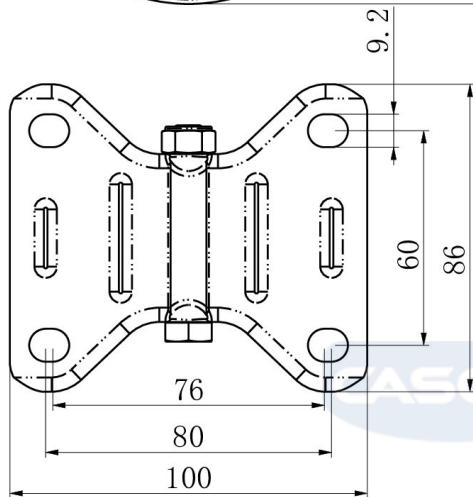
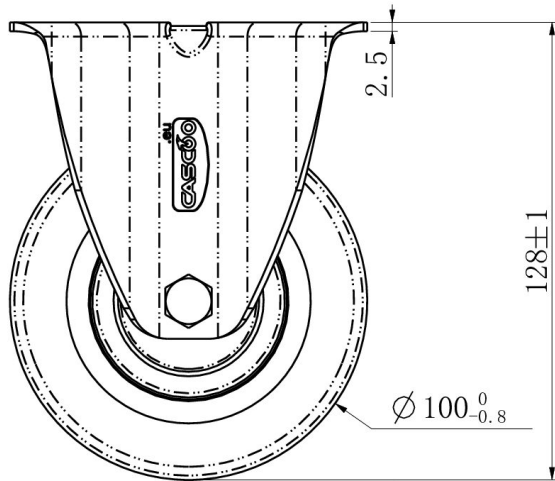

TD_FPP25WC100M6N2B32		
load capacity	160KG	